

FUSE LIST

INDIANA JONES (50017)

POWER DRIVER BOARD		
F101	+50V DC General (Left Flipper)	3A, 250V, SB
F102	+50V DC General (Right Flipper)	3A, 250V, SB
F103	Solenoids #25 to #28	3A, 250V, SB
F104	Solenoids #9 to #16	3A, 250V, SB
F105	Solenoids #1 to #8	3A, 250V, SB
F106	G.I. #5 White-Violet	5A, 250V, SB
F107	G.I. #4 White-Green	5A, 250V, SB
F108	G.I. #3 White-Yellow	5A, 250V, SB
F109	G.I. #2 White-Orange	5A, 250V, SB
F110	G.I. #1 White-Brown	5A, 250V, SB
F111	Flasher Secondary	5A, 250V, SB
F112	Solenoid Secondary	7A, 250V, SB
F113	+5V Logic	5A, 250V, SB
F114	+18V Lamp Matrix	8A, 32V, N.B.
F115	+12V Lamp Matrix	3/4A, 250V, FB
F116	+12V Secondary	3A, 250V, SB
Audio Board		
F501	-25V	3A, 250V, SB
F502	+25V	3A, 250V, SB
Dot Matrix Controller Board		
F601	+62V	3/8A, 250V, FB
F602	-113V & -125V	3/8A, 250V, FB
LINE FILTER		
Foreign		5A, 250V, SB
Domestic		8A, 250V, SB

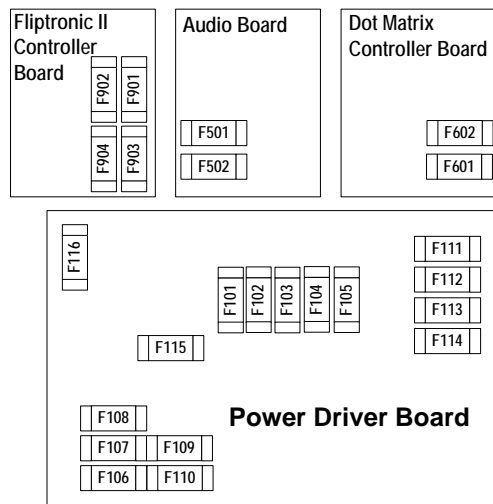

Fliptronic II Controller Board		
F901	Upper Right Flipper	3A, 250V, SB
F902	Upper Left Flipper	3A, 250V, SB
F903	Lower Right Flipper	3A, 250V, SB
F904	Lower Left Flipper	3A, 250V, SB

SOLENOID/FLASHER TABLE

Sol No.	Function	Solenoid Type	Voltage Connections			Drive Xistor	Drive Connections			Drive Wire Color	Coil/Flashlamp Type	
			Playfield	Backbox	Cabinet		Playfield	Insert	Cabinet		Playfield	Insert
01	BALL POPPER	High Power	J107-3			Q82	J130-1			VIO-BRN	AE-26-1200	Insert
02	BALL LAUNCH	High Power	J107-3			Q80	J130-2			VIO-RED	AE-23-800	
03	TOTEM DROP UP	High Power	J107-3			Q78	J130-4			VIO-ORG	AE-26-1200	
04	BALL RELEASE	High Power	J107-3			Q76	J130-5			VIO-YEL	AE-26-1500	
05	CENTER DROP BANK	High Power	J107-3			Q64	J130-6			VIO-GRN	AE-26-1200	
06	IDOL RELEASE	High Power	J107-3			Q66	J130-7			VIO-BLU	AE-26-1500	
07	KNOCKER	High Power	J107-3			Q68	J130-8			VIO-BLK	AE-23-800	
08	LEFT EJECT	High Power	J107-3			Q70	J130-9			VIO-GRY	AE-26-1200	
09	LEFT JET BUMPER	Low Power	J107-2			Q58	J127-1			BRN-BLK	AE-26-1200	
10	RIGHT JET BUMPER	Low Power	J107-2			Q56	J127-3			BRN-RED	AE-26-1200	
11	BOTTOM JET BUMPER	Low Power	J107-2			Q54	J127-4			BRN-ORG	AE-26-1200	
12	LEFT SLINGSHOT	Low Power	J107-2			Q52	J127-5			BRN-YEL	AE-27-1200	
13	RIGHT SLINGSHOT	Low Power	J107-2			Q50	J127-6			BRN-GRN	AE-27-1200	
14	LEFT CONTROL GATE	Low Power	J107-2			Q48	J127-7			BRN-BLU	A-14406	
15	RIGHT CONTROL GATE	Low Power	J107-2			Q46	J127-8			BRN-VIO	A-14406	
16	TOTEM DROP DOWN	Low Power	J107-2			Q44	J127-9			BRN-GRY	SM1-26-600	
17	ETERNAL LIFE	Flasher	J107-6	J106-5		Q42	J126-1	J125-1		BLK-BRN	#906	#906 (3)
18	LIGHT JACKPOT	Flasher	J107-6			Q40	J126-2			BLK-RED	#906	
19	SUPER JACKPOT	Flasher	J107-6			Q38	J126-3			BLK-ORG	#89	
20	JACKPOT	Flasher	J107-6	J106-5		Q36	J126-4	J125-5		BLK-YEL	#89	#906 (2)
21	PATH OF ADVENTURE	Flasher	J107-6	J106-5		Q28	J126-5	J125-6		BLU-GRN	#89	#906 (4)
22	MINI MOTOR LEFT	Low Power	J118-2			Q30	J126-6			BLU-BLK		
23	MINI MOTOR RIGHT	Low Power	J118-2			Q34	J126-7			BLU-VIO	14-7988	
24	PLANE GUN LEDS	Flasher	J118-2	J106-5		Q32	J126-8			BLU-GRY	A-16834	
25	DOGFIGHT HURRY UP	Gen. Purpose	J107-6			Q26	J122-1			BLU-BRN	#89	
26	RIGHT RAMP	Gen. Purpose	J107-6	J106-5		Q24	J122-2	J124-2		BLU-RED	#89 (3)	#906
27	LEFT RAMP	Gen. Purpose	J107-6	J106-5		Q22	J122-3	J124-3		BLU-ORG	#89	#906
28	SUBWAY RELEASE	Gen. Purpose	J107-1			Q20	J122-4			BLU-YEL	AE-26-1500	
37	LEFT SIDE FLASHER	Low Power	J107-6	J106-5		Q16	* J4-2	J4-2		BRN-WHT	#89 (2)	#906
38	RIGHT SIDE FLASHER	Low Power	J107-6	J106-5		Q15	* J4-4	J4-4		BLK-WHT	#89 (2)	#906
39	SPECIAL FLASHER	Low Power	J107-6			Q14	* J4-5			ORG-WHT	#89 (2)	
40	TOTEM MULTIBALL	Low Power	J107-6			Q13	* J4-6			YEL-WHT	#89	
41	JACKPOT MULTIPLIER FLSH	Low Power	J107-6			Q9	* J3-2			GRN-WHT	#89	
42	WHEEL MOTOR	Low Power	J118-2			Q10	* J3-3			BLU-WHT	14-7982	
General Illumination			Voltage Connections			Drive Xistor	Drive Connections			Drive Wire	Bulb Type	
			Playfield	Insert	Cabinet		Playfield	Insert	Cabinet		Playfield	Insert
01	TOP PLAYFIELD	G.I.	J121-1			Q18	J121-7			WHT-BRN	#44	
02	BOTTOM PLAYFIELD	G.I.	J121-2			Q10	J121-8			WHT-ORG	#44	
03	INSERT TOP	G.I.		J120-3		Q14		J120-9		WHT-YEL		#555
04	INSERT BOTTOM	G.I.		J120-4		Q16		J120-10		WHT-GRN		#555
05	RETURN LANE / COIN	G.I.	J121-6		J119-3	Q12	J121-11		J119-1	WHT-VIO	#44	
Flipper Circuits			Playfield Voltage Connection		Drive Transistors		Playfield Drive Connections		Drive Wire Colors		Coil Part No. / Colors	
			Power	Hold	Power	Hold	Power	Hold	Power	Hold	Part No.	Colors
29	LOWER RIGHT FLIPPER		J907-9 (BLU-YEL)		Q4		J902-13		BLU-VIO		FL-11629	BLUE
30			J907-9 (BLU-YEL)		Q11		J902-11		ORG-GRN			
31	LOWER LEFT FLIPPER		J907-7 (GRY-YEL)		Q3		J902-9		BLU-GRY		FL-11629	BLUE
32			J907-7 (GRY-YEL)		Q9		J902-7		ORG-BLU			
33	DIVERTER		J907-1 (BLU-YEL)		Q2		J902-6		BLK-YEL		FL-11753-1	YELLOW
34			J907-1 (BLU-YEL)		Q7		J902-4		ORG-VIO			
35	TOP LOCKUP		J907-4 (GRY-YEL)		Q1		J902-3		BLK-BLU		A-15943	BROWN
36			J907-4 (GRY-YEL)		Q5		J902-1		ORG-GRY			

* From 8 Driver PCB, A-16100

** From D.C. Motor Control Assembly, A-16120

LAMP MATRIX

Column	Row	1	2	3	4	5	6	7	8
		Yellow-Brown J137-1 Q98	Yellow-Red J137-2 Q97	Yellow-Orange J137-3 Q96	Yellow-Black J137-4 Q95	Yellow-Green J137-5 Q94	Yellow-Blue J137-6 Q93	Yellow-Violet J137-7 Q92	Yellow-Grey J137-9 Q91
1 Red-Brown J133-1 Q90	MODE START	TANK CHASE	LEFT RAMP ARROW	MINE CART	CHOOSE WISELY	(I)NDY	MINI TOP LEFT	MINI MIDDLE BOTTOM LEFT	
2 Red-Black J133-2 Q89	HAND OF FATE	ADVEN(T)URE LIGHT	CASTLE GRUNEWALD	ARK JACKPOT	RIGHT PLANE TOP	(N)DY	MINI TOP RIGHT	MINI MIDDLE BOTTOM RIGHT	
3 Red-Orange J133-4 Q88	EJECT EXTRA BALL	ADV(E)NTURE LIGHT	LEFT PLANE TOP	RAVEN BAR	ROPE BRIDGE	IN(D)Y	MINI MIDDLE TOP LEFT	MINI BOTTOM LEFT	
4 Red-Yellow J133-5 Q87	AD(V)ENTURE LIGHT	ADVE(N)TURE LIGHT	MONKEY BRAINS	RIGHT PLANE MIDDLE	ADVENT(U)RE LIGHT	IND(Y)	MINI MIDDLE TOP RIGHT	MINI BOTTOM RIGHT	
5 Red-Green J133-6 Q86	A(D)VENTURE LIGHT	STEAL THE STONES	LEFT PLANE MIDDLE	BONUS 6 X	ADVENTU(R)E LIGHT	WILLIE	MINI ARROW TOP	MINI BOTTOM ARROW	
6 Red-Blue J133-7 Q85	(A)DVENTURE LIGHT	GRAIL JACKPOT	SALLAH	RIGHT PLANE BOTTOM	ADVENTUR(E) LIGHT	BONUS 2 X	MARION	TOTEM TOP ARROW	
7 Red-Violet J133-8 Q84	SHOOT AGAIN	STREETS OF CAIRO	BONUS 4 X	WELL OF SOULS	THE 3 CHALLENGES	SHORTY	BONUS 8 X	CENTER LOCK	
8 Red-Grey J133-9 Q83	GET THE IDOL	STONES JACKPOT	LEFT PLANE BOTTOM	LEFT LOOP	RIGHT LOOP	RIGHT RAMP ARROW	DR. JONES	START BUTTON	

J1XX = Power Driver Board

SWITCH MATRIX

Column	Row	1	2	3	4	5	6	7	8	9	FLIPPER GROUNDED SWITCHES
		Green-Brown J207-1 U20-18	Green-Red J207-2 U20-17	Green-Orange J207-3 U20-16	Green-Yellow J207-4 U20-15	Green-Black J207-5 U20-14	Green-Blue J207-6 U20-13	Green-Violet J207-7 U20-12	Green-Grey J207-9 U20-11	Grey-White *J5-4 Q11	
Orange-Brown J205-1 LEFT COIN CHUTE	1 White-Brown J209-1 U18-11	SINGLE DROP TARGET	SLAM TILT	LEFT EJECT	LEFT RAMP ENTER	ADVENT-(U)RE TARGET	(A)DVENT-URE TARGET	CAPTIVE BALL FRONT	TROUGH 6	WHEEL POSITION 1	Black-Green J906-1 Lower Right Flipper E.O.S.
Orange-Red J205-2 CENTER COIN CHUTE	2 White-Red J209-2 U18-9	BUY-IN BUTTON	COIN DOOR CLOSED	EXIT IDOL	RIGHT RAMP ENTER	ADVENT-U(R)E TARGET	A(D)VENT-URE TARGET	MINI TOP HOLE	TROUGH 5	WHEEL POSITION 2	Black-Violet J905-1 Lower Right Flipper Opto
Orange-Black J205-3 RIGHT COIN CHUTE	3 White-Orange J209-3 U18-5	START BUTTON	TICKET OPTO	LEFT SLINGSHOT	TOP IDOL ENTER	ADVENT-UR(E) TARGET	AD(V)ENT-URE TARGET	MINI BOTTOM HOLD	TROUGH 4	WHEEL POSITION 3	Black-Blue J906-3 Lower Left Flipper E.O.S.
Orange-Yellow J205-4 4 TH COIN CHUTE	4 White-Yellow J209-4 U18-7	PLUMB BOB TILT	ALWAYS CLOSED	GUN TRIGGER	RIGHT POPPER	LEFT LOOP TOP	CAPTIVE BALL BACK	RIGHT RAMP MADE	TROUGH 3	MINI PLAYFIELD LEFT LIMIT	Black-Gray J905-2 Lower Left Flipper Opto
Orange-Green J205-6	5 White-Green J209-5 U19-11	LEFT OUTLANE	(I)NDY LANE	LEFT JET	CENTER ENTER	LEFT LOOP BOTTOM	MINI TOP LEFT	MINI TOP RIGHT	TROUGH 2	MINI PLAYFIELD RIGHT LIMIT	Black-Violet J906-4 Upper Right Flipper E.O.S.
Orange-Blue J205-7	6 White-Blue J209-7 U19-9	LEFT RETURN LANE	(N)DY LANE	RIGHT JET	TOP POST	RIGHT LOOP TOP	MINI MIDDLE TOP LEFT	MINI MIDDLE TOP RIGHT	TROUGH 1		Black-Yellow J905-3 Upper Right Flipper Opto
Orange-Violet J205-8	7 White-Violet J209-8 U19-5	RIGHT RETURN LANE	IN(D)Y LANE	BOTTOM JET	SUBWAY LOCKUP	RIGHT LOOP BOTTOM	MINI MIDDLE BOTTOM LEFT	MINI MIDDLE BOTTOM RIGHT	TOP TROUGH		Black-Gray J906-5 Upper Left Flipper E.O.S.
Orange-Grey J205-9	8 White-Grey J209-9 U19-7	RIGHT OUTLANE TOP	IND(Y) LANE	CENTER STANDUP	RIGHT SLINGSHOT	RIGHT OUTLANE BOTTOM	MINI BOTTOM LEFT	MINI BOTTOM RIGHT	SHOOTER		Black-Blue J905-5 Upper Left Flipper Opto

J2XX = CPU Board; J9XX = Fliptronic II Board;

= OPTO, TYPICALLY CLOSED *Located on 8 driver PCB, A-16100, in backbox