

FUSE LIST

POWER DRIVER BOARD		
F101	+50V DC General (Left Flipper)	3A, 250V, SB
F102	+50V DC General (Right Flipper)	3A, 250V, SB
F103	Solenoids #25 to #28	3A, 250V, SB
F104	Solenoids #9 to #16	3A, 250V, SB
F105	Solenoids #1 to #8	3A, 250V, SB
F106	G.I. #5 White-Violet	5A, 250V, SB
F107	G.I. #4 White-Green	5A, 250V, SB
F108	G.I. #3 White-Yellow	5A, 250V, SB
F109	G.I. #2 White-Orange	5A, 250V, SB
F110	G.I. #1 White-Brown	5A, 250V, SB
F111	Flasher Secondary	5A, 250V, SB
F112	Solenoid Secondary	7A, 250V, SB
F113	+5V Logic	5A, 250V, SB
F114	+18V Lamp Matrix	8A, 32V, N.B.
F115	+12V Lamp Matrix	3/4A, 250V, FB
F116	+12V Secondary	3A, 250V, SB

Audio Board		
F501	-25V	3A, 250V, SB
F502	+25V	3A, 250V, SB

Dot Matrix Controller Board		
F601	+62V	3/8A, 250V, FB
F602	-113V & -125V	3/8A, 250V, FB

LINE FILTER		
Foreign		5A, 250V, SB
Domestic		8A, 250V, SB

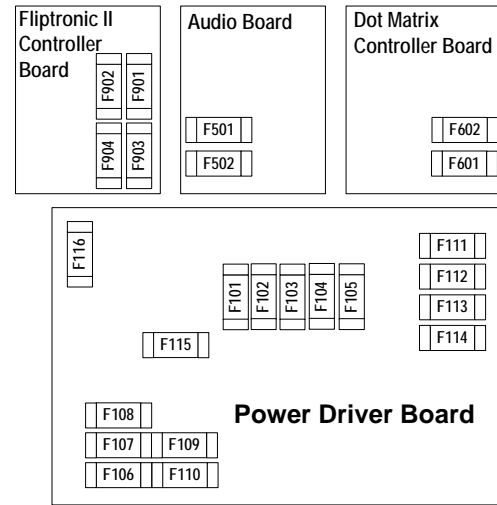

Fliptronic II Controller Board		
F901	Upper Right Flipper	3A, 250V, SB
F902	Upper Left Flipper	3A, 250V, SB
F903	Lower Right Flipper	3A, 250V, SB
F904	Lower Left Flipper	3A, 250V, SB

SOLENOID/FLASHER TABLE

Sol No.	Function	Solenoid Type	Voltage Connections			Drive Xistor	Drive Connections			Drive Wire Color	Solenoid Part Number Flashlamp Type	
			Playfield	Backbox	Cabinet		Playfield	Insert	Cabinet		Playfield	Insert
01	BALL TROUGH	High Power	J107-2			Q82	J130-1			VIO-BRN	AE-26-1500	
02	MAGNET DIVERTER	High Power	J107-2			Q80	J130-2			VIO-RED	20-10179	
03	TRAP DOOR UP	High Power	J107-2			Q78	J130-4			VIO-ORG	A-20099	
04	SUBWAY POPPER	High Power	J107-2			Q76	J130-5			VIO-YEL	AE-26-1200	
05	RIGHT DRAIN MAGNET	High Power	J107-2			Q64	J130-6			VIO-GRN	20-10197	
06	CENTER LOOP POST	High Power	J107-2			Q66	J130-7			VIO-BLU	AE-27-1200	
07	KNOCKER	High Power		J107-2		Q68		J130-8		VIO-BLK		AE-23-800
08	TOP DIVERTER POST	High Power	J107-2			Q70	J130-9			VIO-GRY	AE-27-1200	
09	LEFT SLINGSHOT	Low Power	J107-3			Q58	J127-1			BRN-BLK	AE-27-1200	
10	RIGHT SLINGSHOT	Low Power	J107-3			Q56	J127-3			BRN-RED	AE-27-1200	
11	BOTTOM JET BUMPER	Low Power	J107-3			Q54	J127-4			BRN-ORG	AE-26-1200	
12	MIDDLE JET BUMPER	Low Power	J107-3			Q52	J127-5			BRN-YEL	AE-26-1200	
13	TOP JET BUMPER	Low Power	J107-3			Q50	J127-6			BRN-GRN	AE-26-1200	
14	TRAP DOOR HOLD	Low Power	J107-2			Q48	J127-7			BRN-BLU	A-20099	
15	LEFT UP/DOWN GATE	Low Power	J107-3			Q46	J127-8			BRN-VIO	A-14406	
16	RIGHT UP/DOWN GATE	Low Power	J107-3			Q44	J127-9			BRN-GRY	A-14406	
17	BOX CLOCKWISE	Flasher	J116-2			Q42	J126-1			BLK-BRN	14-8018	
18	BOX COUNTER CLOCKWISE	Flasher	J116-2			Q40	J126-2			BLK-RED	14-8018	
19	NOT USED	Flasher	J116-2			Q38	J126-3			BLK-ORG	--	
20	RETURN LANE FLASHER	Flasher	J107-6			Q36	J126-4			BLK-YEL	#89 (2)	
21	TOP KICKOUT	Flasher	J107-1			Q28	+ J126-5			BLU-GRN	AE-27-1200	
22	NOT USED	Flasher	J107-6			Q30	J126-6			BLU-BLK	--	
23	NOT USED	Flasher	J107-6			Q34	J126-7			BLU-VIO	--	
24	TRAP DOOR FLASHER	Flasher	J107-6			Q32	J126-8			BLU-GRY	#89 (2)	
25	SPIRIT RING FLASHER	Gen. Purpose	J107-6	J106-5		Q26	J122-1	J124-1		BLU-BRN	#906, #89	#906
26	SAW FLASHER	Gen. Purpose	J107-6	J106-5		Q24	J122-2	J124-2		BLU-RED	#906, #89(2)	#906
27	JET FLASHER	Gen. Purpose	J107-6	J106-5		Q22	J122-3	J124-3		BLU-ORG	#906, #89(2)	#906
28	BOX FLASHER	Gen. Purpose	J107-6	J106-5		Q20	J122-4	J124-5		BLU-YEL	#906, #89(2)	#906
33	CUBE MAGNET	High Power	J907-6,7			Q2	J902-6			YEL-VIO	20-10197	
34	SUB BALL RELEASE	Low Power	J907-6,7			Q7	J902-4			ORG-VIO	AE-27-1200	
35	LEFT DRAIN MAGNET	High Power	J907-8,9			Q1	J902-3			YEL-GRY	20-10197	

General Illumination		Voltage Connections			Drive Xistor	Drive Connections			Drive Wire	Bulb Type	
		Playfield	Insert	Cabinet		Playfield	Insert	Cabinet		Playfield	Insert
01	ILLUMINATION STRING 1	G.I.	J120-7		Q18		J120-7		WHT-BRN		#555
02	ILLUMINATION STRING 2	G.I.	J120-2		Q10		J120-8		WHT-ORG		#555
03	ILLUMINATION STRING 3	G.I.	J121-3		Q14	J121-9			WHT-YEL	#44	
04	ILLUMINATION STRING 4	G.I.	J131-5		Q16	J121-10			WHT-GRN	#44	
05	ILLUMINATION STRING 5	G.I.	J121-6		Q12	J121-11			WHT-VIO	#44	

Flipper Circuits		Power	Playfield Voltage Connection	Drive Transistors Power	Hold	Playfield Drive Connections			Drive Wire Colors	Coil Part No.	Coil Colors
						Playfield	Insert	Cabinet			
29	LOWER RIGHT FLIPPER	Power	J907-1 (RED-GRN)	Q4		J902-13			YEL-GRN	FL-11629	BLUE
30		Hold	J907-1 (RED-GRN)		Q11		J902-11			ORG-GRN	
31	LOWER LEFT FLIPPER	Power	J907-4 (RED-BLU)	Q3		J902-9			YEL-BLU	FL-11629	BLUE
32		Hold	J907-4 (RED-BLU)		Q9		J902-7			ORG-BLU	
33		Power	J907-6 (RED-VIO)	Q2		J902-6			YEL-VIO	--	--
34	NOT USED	Hold	J907-6 (RED-VIO)		Q7	J902-4			ORG-VIO		
35		Power	J907-8 (RED-GRY)	Q1		J902-3			YEL-GRY	--	--
36	NOT USED	Hold	J907-8 (RED-GRY)		Q5	J920-1			ORG-GRY		

J1xx = Power Driver Board

J9xx = Fliptronic II Board + Tieback Diode J126-13

LAMP MATRIX

Column	Row	1	2	3	4	5	6	7	8
		Yellow-Brown J137-1 Q98	Yellow-Red J137-2 Q97	Yellow-Orange J137-3 Q96	Yellow-Black J137-4 Q95	Yellow-Green J137-5 Q94	Yellow-Blue J137-6 Q93	Yellow-Violet J137-7 Q92	Yellow-Grey J137-9 Q91
1 Red-Brown J133-1 Q90	(T)HEATRE	HAUNTED BASEMENT	MA(G)IC	EXTRA BALL	TRUNK HIT 2	TIGER SAW	HAT MAGIC	SPECIAL	
2 Red-Black J133-2 Q89	T(H)EATRE	META-MORPHISIS AWARD	MAG(C)	VANISH	HURRY UP	LEVITATE WOMAN	SPIRIT AWARD	NOT USED	
3 Red-Orange J133-4 Q88	TH(E)ATRE	RIGHT SPELL MAGIC	LIFT TRAPDOOR	SPELL THEATRE	TRUNK ESCAPE	GRAND FINALE	THEATRE	NOT USED	
4 Red-Yellow J133-5 Q87	THE(A)TRE	SPIRIT RING	CENTER SPELL MAGIC	JACKPOT	LOCK BALL	TRUNK ESCAPE	MULTI-BALL	NOT USED	
5 Red-Green J133-6 Q86	THEA(T)RE	ADVANCE CLOCK	LEVITATE AWARD	SAFE AWARD	HAT TRICK AWARD	SPIRIT CARDS	MIDNIGHT	LAMP IN CUBE	
6 Red-Blue J133-7 Q85	THEAT(R)E	JACKET AWARD	MAG(I)C	TIGER SAW AWARD	START ILLUSION	SAFE ESCAPE	ILLUSIONS	SHOOT AGAIN	
7 Red-Violet J133-8 Q84	THEATR(E)	M(A)GIC	TOP ROLLOVER 1	START FINALE	START MULTIBALL	META-MORPHISIS	SAW MULTI-BALL	BUY-IN	
8 Red-Grey J133-9 Q83	(M)AGIC	TRUNK HIT 3	TOP ROLLOVER 2	TRUNK HIT 1	LITE VANISH	STRAIT JACKET	HOCUS POCUS	START BUTTON	

J1XX = Power Driver Board

SWITCH MATRIX

DEDICATED GROUNDED SWITCHES	Column	Row	1	2	3	4	5	6	7	8	FLIPPER GROUNDED SWITCHES
			Green-Brown J207-1 U20-18	Green-Red J207-2 U20-17	Green-Orange J207-3 U20-16	Green-Yellow J207-4 U20-15	Green-Black J207-5 U20-14	Green-Blue J207-6 U20-13	Green-Violet J207-7 U20-12	Green-Grey J207-9 U20-11	
Orange-Brown J205-1 LEFT COIN CHUTE U17-5	D1	1 White-Brown J209-1 U18-11	NOT USED	SLAM TILT	TROUGH JAM	LOCK 1	LEFT BANK TARGET	LEFT SLING	CENTER RAMP EXIT	LOOP RIGHT	Black-Green J906-1 Lower Right Flipper E.O.S.
Orange-Red J205-2 CENTER COIN CHUTE U17-7	D2	2 White-Red J209-2 U18-9	NOT USED	COIN DOOR CLOSED	TROUGH BALL 1	LOCK 2	CAPTIVE BALL REST	RIGHT SLING	NOT USED	CENTER RAMP TARGETS	Black-Violet J905-1 Lower Right Flipper Opto
Orange-Black J205-3 RIGHT COIN CHUTE U17-11	D3	3 White-Orange J209-3 U18-5	START BUTTON	BUY-IN	TROUGH BALL 2	LOCK 3	RIGHT LANE ENTER	BOTTOM JET	RIGHT RAMP EXIT	VANISH LOCK 1	Black-Blue J906-3 Lower Left Flipper E.O.S.
Orange-Yellow J205-4 4TH COIN CHUTE U17-9	D4	4 White-Yellow J209-4 U18-7	PLUMB BOB TILT	ALWAYS CLOSED	TROUGH BALL 3	POPPER	LEFT LANE ENTER	MIDDLE JET	RIGHT RAMP EXIT 2	VANISH LOCK 2	Black-Gray J905-2 Lower Left Flipper Opto
Orange-Green J205-6 Normal Function Srv Crdts	D5	5 White-Green J209-5 U19-11	SHOOTER LANE	LEFT OUTLANE	TROUGH BALL 4	LEFT DRAIN EDDY	CUBE POSITION 4	TOP JET	CENTER RAMP ENTER	TRUNK HIT	Black-Violet J906-4 Upper Right Flipper E.O.S.
Orange-Blue J205-7 Normal Function Volume Dn	D6	6 White-Blue J209-7 U19-9	NOT USED	LEFT RETURN LANE	SUBWAY OPTO	NOT USED	CUBE POSITION 1	TOP LANE 1	RIGHT RAMP ENTER	RIGHT LANE EXIT	Black-Yellow J905-3 Upper Right Flipper Opto
Orange-Violet J205-8 Normal Function Volume Up	D7	7 White-Violet J209-8 U19-5	NOT USED	RIGHT RETURN LANE	SPINNER	SUBWAY MICRO	CUBE POSITION 2	TOP LANE 2	CAPTIVE BALL TOP	LEFT LANE EXIT	Black-Gray J906-5 Upper Left Flipper E.O.S.
Orange-Grey J205-9 Normal Function Begin Test	D8	8 White-Grey J209-9 U19-7	NOT USED	RIGHT OUTLANE	RIGHT LOWER TARGET	RIGHT DRAIN EDDY	CUBE POSITION 3	NOT USED	LOOP LEFT	NOT USED	Black-Blue J905-5 Upper Left Flipper Opto

J2XX = CPU Board; J9XX = Fliptronic II Board

= OPTO, TYPICALLY CLOSED